

# JVC

# SERVICE MANUAL

## AUDIO/VIDEO CONTROL RECEIVER

# RX-8010VBK

Area Suffix

J-----U.S.A.

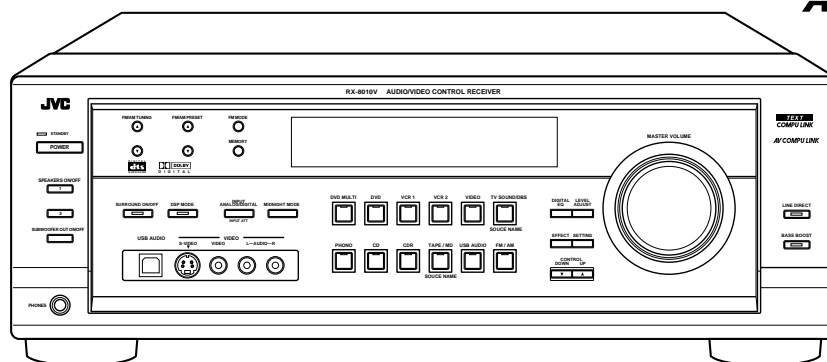
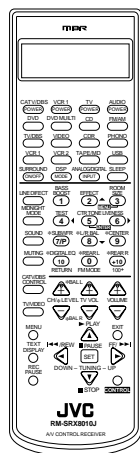

**AV COMPU LINK**

**TEXT  
COMPU LINK**

DIGITAL  
**dts**  
SURROUND

**DOLBY**  
DIGITAL

### Contents

Safety precautions .....	1-2
Importance administering point on the safety .....	1-3
Disassembly method .....	1-4
Adjustment method .....	1-10
Self-diagnose function .....	1-11
Description of major ICs .....	1-13

## Safety Precautions

1. This design of this product contains special hardware and many circuits and components specially for safety purposes. For continued protection, no changes should be made to the original design unless authorized in writing by the manufacturer. Replacement parts must be identical to those used in the original circuits. Services should be performed by qualified personnel only.
2. Alterations of the design or circuitry of the product should not be made. Any design alterations of the product should not be made. Any design alterations or additions will void the manufacturer's warranty and will further relieve the manufacture of responsibility for personal injury or property damage resulting therefrom.
3. Many electrical and mechanical parts in the products have special safety-related characteristics. These characteristics are often not evident from visual inspection nor can the protection afforded by them necessarily be obtained by using replacement components rated for higher voltage, wattage, etc. Replacement parts which have these special safety characteristics are identified in the Parts List of Service Manual. Electrical components having such features are identified by shading on the schematics and by ( $\triangle$ ) on the Parts List in the Service Manual. The use of a substitute replacement which does not have the same safety characteristics as the recommended replacement parts shown in the Parts List of Service Manual may create shock, fire, or other hazards.
4. The leads in the products are routed and dressed with ties, clamps, tubings, barriers and the like to be separated from live parts, high temperature parts, moving parts and/or sharp edges for the prevention of electric shock and fire hazard. When service is required, the original lead routing and dress should be observed, and it should be confirmed that they have been returned to normal, after re-assembling.
5. Leakage current check (Electrical shock hazard testing)  
After re-assembling the product, always perform an isolation check on the exposed metal parts of the product (antenna terminals, knobs, metal cabinet, screw heads, headphone jack, control shafts, etc.) to be sure the product is safe to operate without danger of electrical shock. Do not use a line isolation transformer during this check.

- Plug the AC line cord directly into the AC outlet. Using a "Leakage Current Tester", measure the leakage current from each exposed metal parts of the cabinet, particularly any exposed metal part having a return path to the chassis, to a known good earth ground. Any leakage current must not exceed 0.5mA AC (r.m.s.)

- Alternate check method

Plug the AC line cord directly into the AC outlet. Use an AC voltmeter having, 1,000 ohms per volt or more sensitivity in the following manner. Connect a 1,500 $\Omega$  10W resistor paralleled by a 0.15 $\mu$ F AC-type capacitor between an exposed metal part and a known good earth ground.

Measure the AC voltage across the resistor with the AC voltmeter.

Move the resistor connection to each exposed metal part, particularly any exposed metal part having a return path to the chassis, and measure the AC voltage across the resistor. Now, reverse the plug in the AC outlet and repeat each measurement. voltage measured Any must not exceed 0.75 V AC (r.m.s.). This corresponds to 0.5 mA AC (r.m.s.).

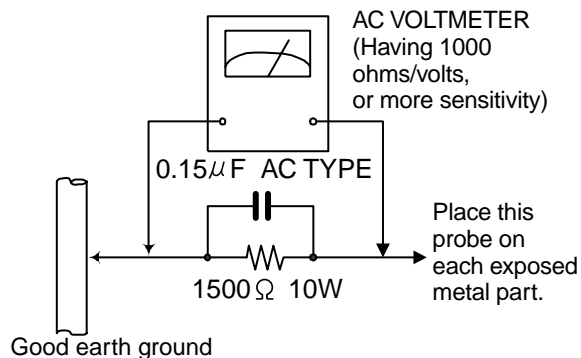

## Warning

1. This equipment has been designed and manufactured to meet international safety standards.
2. It is the legal responsibility of the repairer to ensure that these safety standards are maintained.
3. Repairs must be made in accordance with the relevant safety standards.
4. It is essential that safety critical components are replaced by approved parts.
5. If mains voltage selector is provided, check setting for local voltage.

**CAUTION** Burrs formed during molding may be left over on some parts of the chassis. Therefore, pay attention to such burrs in the case of preforming repair of this system.

## Importance administering point on the safety

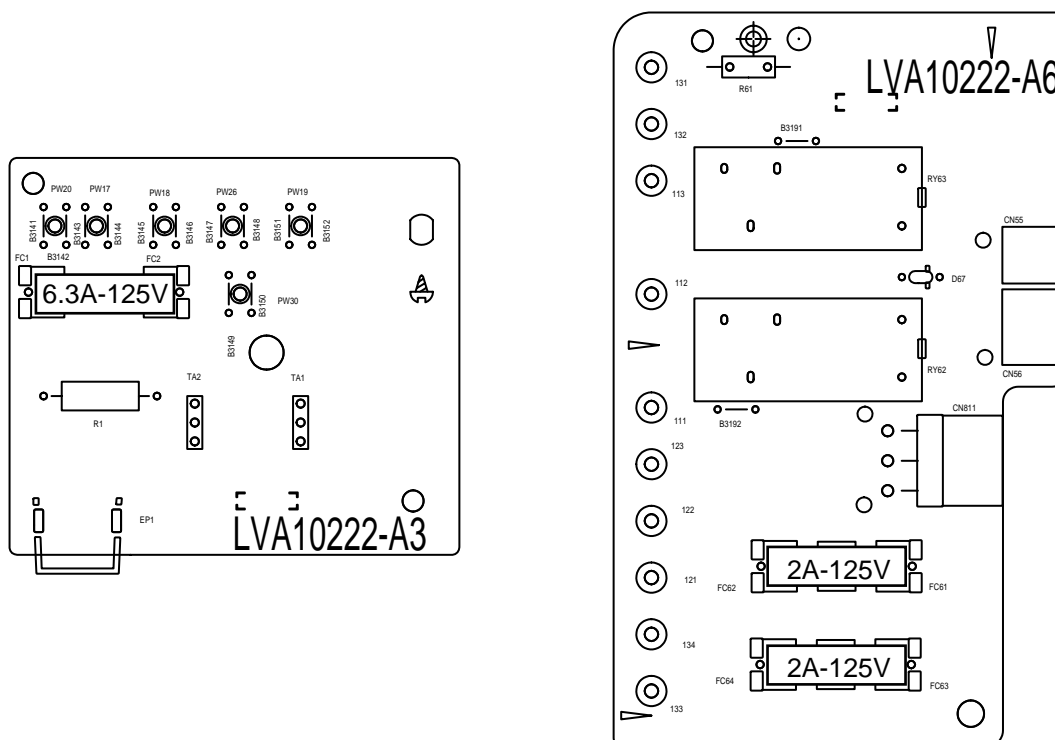

For USA and Canada / pour États - Unis d'Amérique et Canada

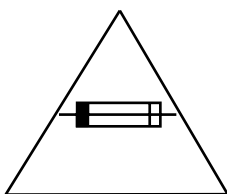

Caution: For continued protection against risk of fire, replace only with same type 6.3A/125V for F201, 2A/125V for F202 and F203. This symbol specifies type of fast operating fuse.

Précaution: Pour éviter risques de feux, remplacez le fusible de sûreté de F201 comme le même type que 6.3A/125V, et 2A/125V pour F202 et F203. Ce sont des fusibles sûretés qui fonctionnent rapide.

## Disassembly method

### ■ Removing the top cover (See Fig.1)

1. Remove the four screws A attaching the top cover on both sides of the body.
2. Remove the three screws B on the back of the body.
3. Remove the top cover from behind in the direction of the arrow while pulling both sides outward.

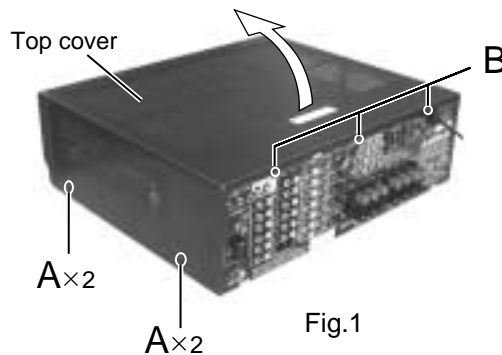

### ■ Removing the front panel assembly (See Fig.2 to 3)

- Prior to performing the following procedure, remove the top cover.
1. Disconnect the card wire from connector CN400 on the audio board and CN402 on the power supply board in the front panel assembly.
  2. Cut off the tie band fixing the harness.
  3. Remove the three screws C attaching the front panel assembly and the screw a fixing a ground.
  4. Remove the four screws D attaching the front panel assembly on the bottom of the body. Detach the front panel assembly toward the front.

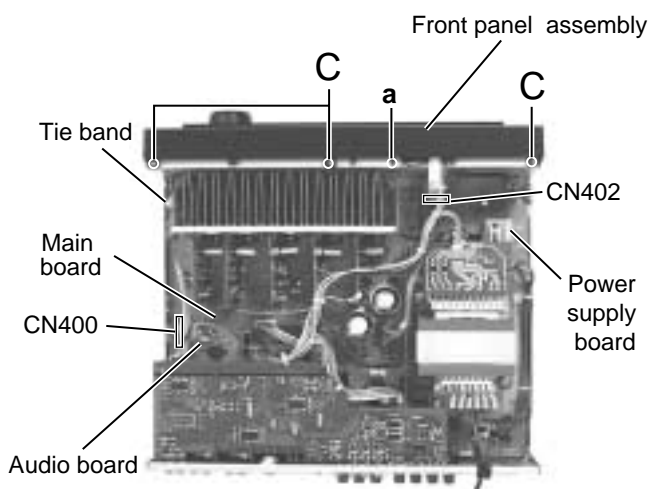

Fig.2

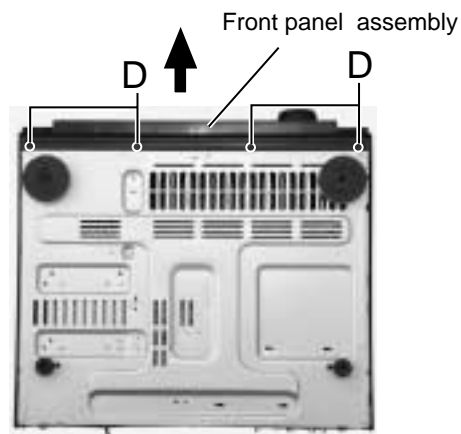

Fig.3

### ■ Removing the rear panel (See Fig.4)

- Prior to performing the following procedure, remove the top cover.
1. Remove the power cord stopper from the rear panel by moving it in the direction of the arrow.
  2. Remove the thirty four screws E attaching the each boards to the rear panel on the back of the body.
  3. Remove the three screws F attaching the rear panel on the back of the body.

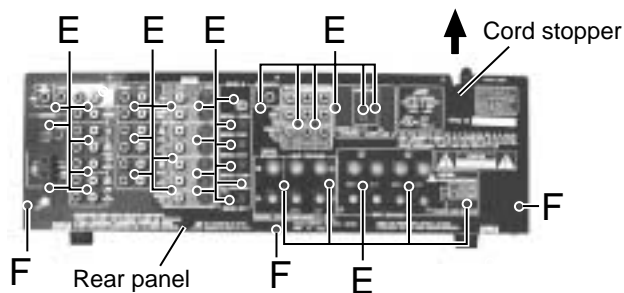

Fig.4

**■ Removing each board connected to the rear side of the audio board**

**(See Fig.5 to 11)**

• Prior to performing the following procedure, remove the top cover and the rear panel.

1. Cut off the tie band fixing the harness.
2. Disconnect the connect CN501, CN243, CN205, CN381, CN361 on the DVD board.
3. Disconnect the harness from connector CN721, CN722 and CN723.
4. Disconnect the tuner board and audio board from connector CN101 and CN301 on the audio board.
5. Pull out the video audio board, video board, S-video board.
6. Disconnect the DSP board from connector CN601 on the audio board.

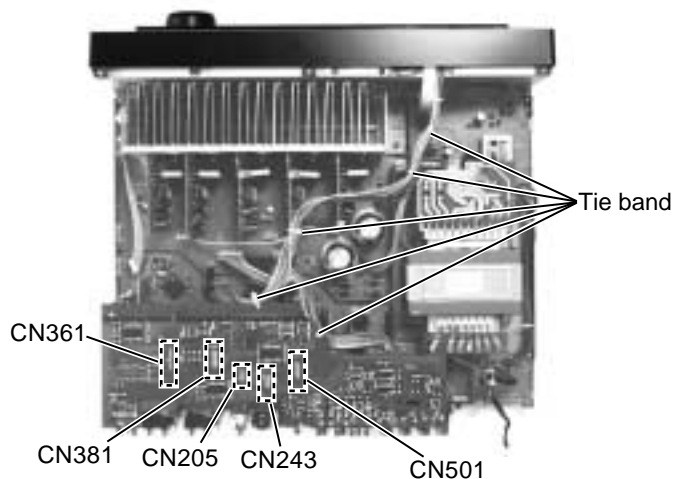

Fig.5

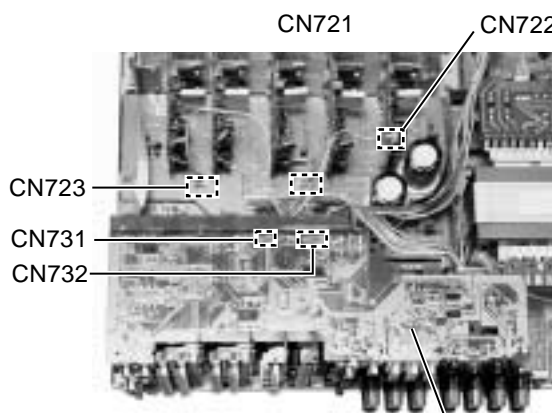

Fig.6

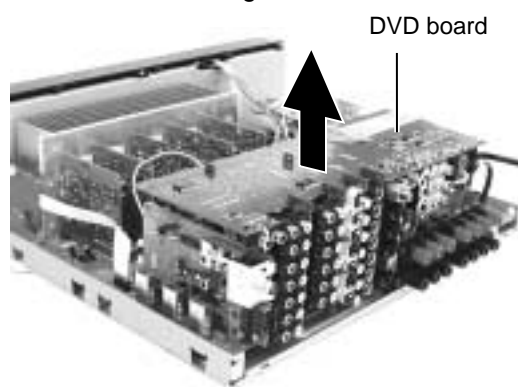

Fig.7

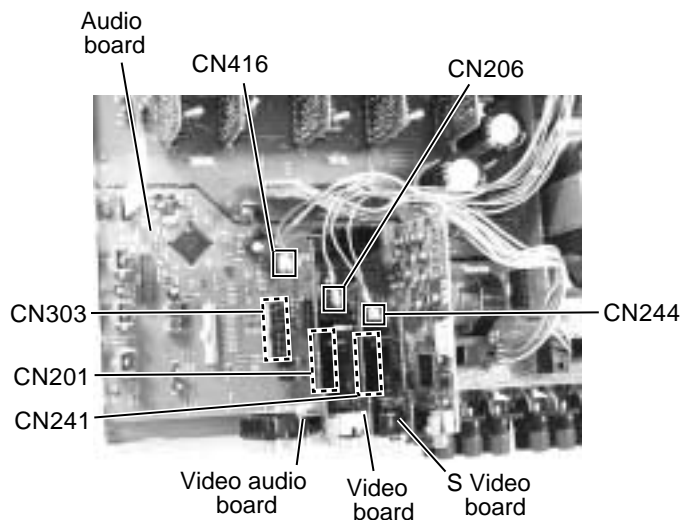

Fig.9

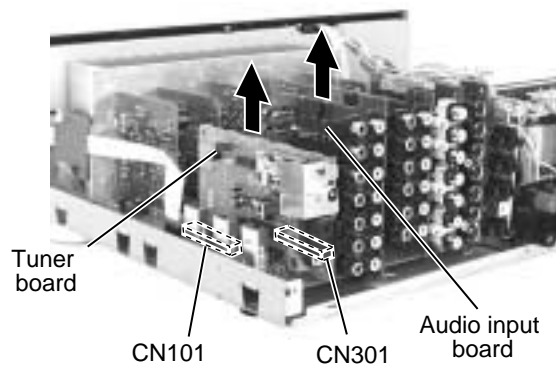

Fig.8

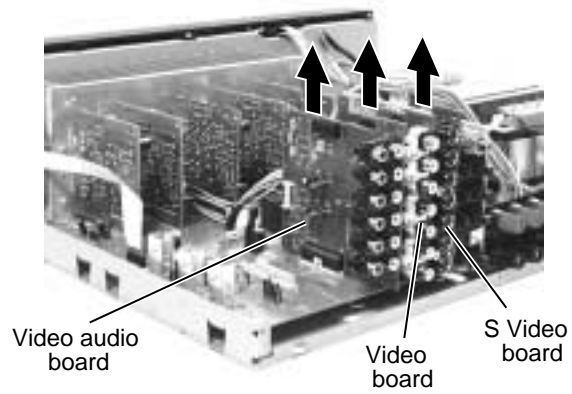

Fig.10

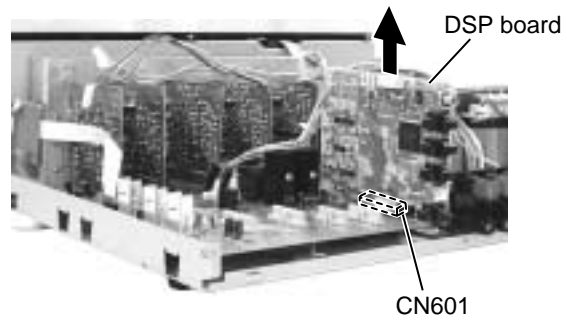

Fig.11

**■ Removing the audio board  
(See Fig.12 to 13)**

- Prior to performing the following procedure, remove the top cover and the rear panel.
- 1. Disconnect the harness from connector CN813 and CN814 on the main board.
- 2. Disconnect the card wire from connector CN931 and CN932 on the audio board.
- 3. Cut off the tie band fixing the harness.
- 4. Disconnect the relay board from the audio board and the power supply board. (CN71,CN81)
- 5. Disconnect the card wire from connector CN831 on the main board.
- 6. Remove the three screws G attaching the audio board assembly.
- 7. Remove the screw H attaching the audio board assembly.

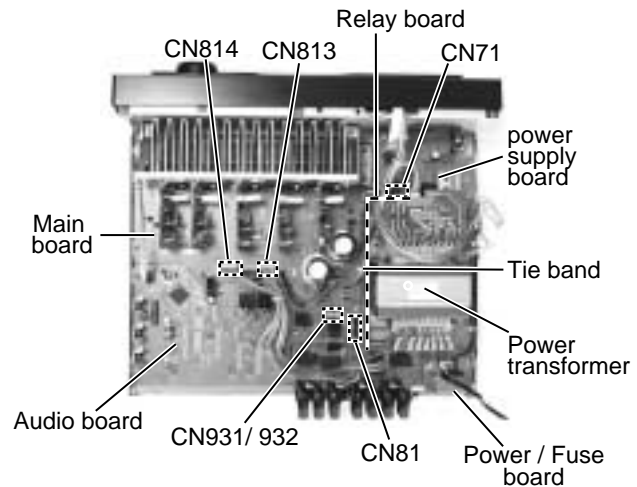

Fig.12

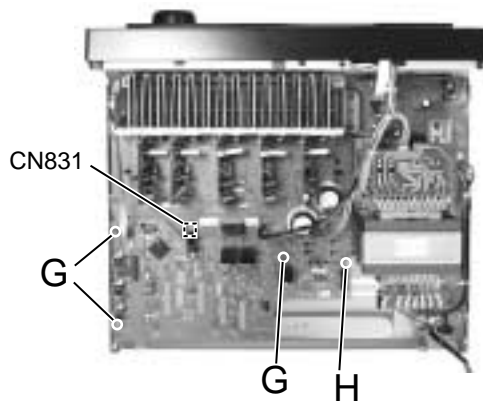

Fig.13

## ■ Removing the main board (See Fig.14)

- Prior to performing the following procedure, remove the top cover, the rear panel and audio board.

1. Cut off the tie band fixing the harness.
2. Disconnect the harness from connector CN811 on the power supply board respectively.
3. Disconnect the harness from connector CN881 on the main board.
4. Remove the four screws I and the two screws J attaching the main board.

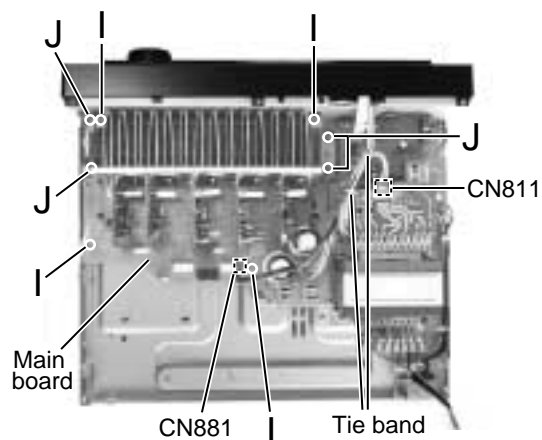

Fig.14

## ■ Removing the Heat sink (See Fig.15 to 16)

1. Remove the ten screws K and four screws L attaching the heat sink.
2. Remove the two screws L' attaching the heat sink from the rear side of main board.

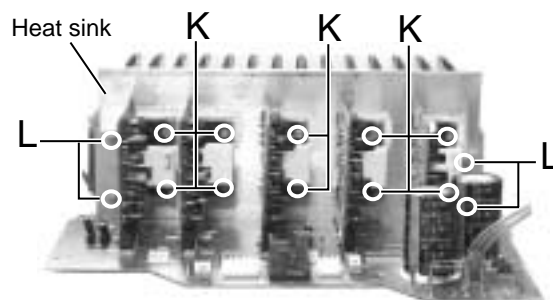

Fig.15

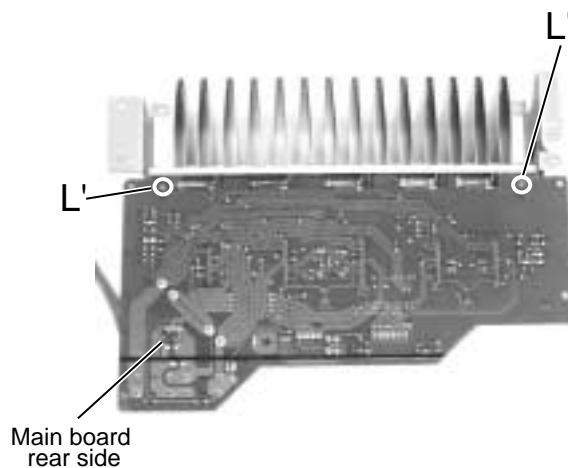

Fig.16

**■ Removing the power transformer**  
(See Fig.17)

• Prior to performing the following procedures, remove the top cover.

1. Unsolder the two harnesses connected to the power transformer.
2. Disconnect the harness from connector CN55 and CN56 on the power transformer board.
3. Remove the four screws M attaching the power transformer.

**■ Removing the power / fuse board**  
(See Fig.17)

• Prior to performing the following procedure, remove the top cover and the rear panel.

1. Remove the screw N attaching the power / fuse board.
2. Unsolder the power cord and other harnesses connected to the power / fuse board.

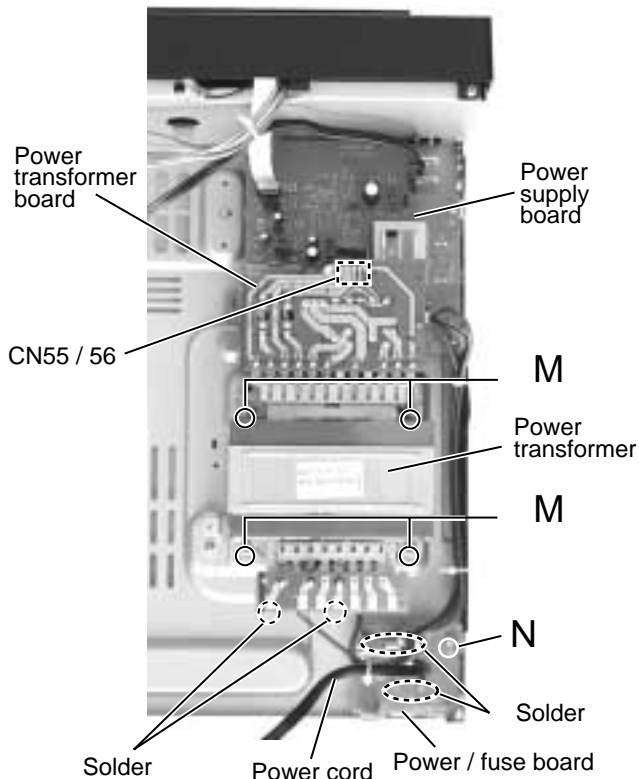

Fig.17

**■ Removing the power supply board**  
(See Fig.18 to 19)

• Prior to performing the following procedure, remove the top cover and the front panel.

1. Remove the screws **b** fixing a bonding ground.
2. Remove the one nut attaching the headphone jack of the power supply board on the front side of the body.
3. Disconnect the card wire from connector CN402 on the power supply board.
4. Remove the three screws **O** attaching the power supply board and pull out the power supply board from the front bracket backward.
5. Unsolder the three harnesses connected to the power supply board.

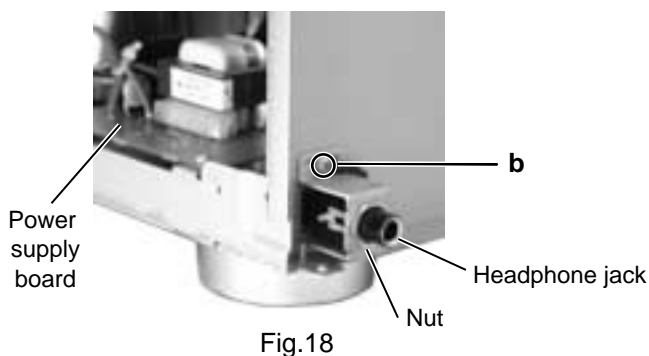

Fig.18

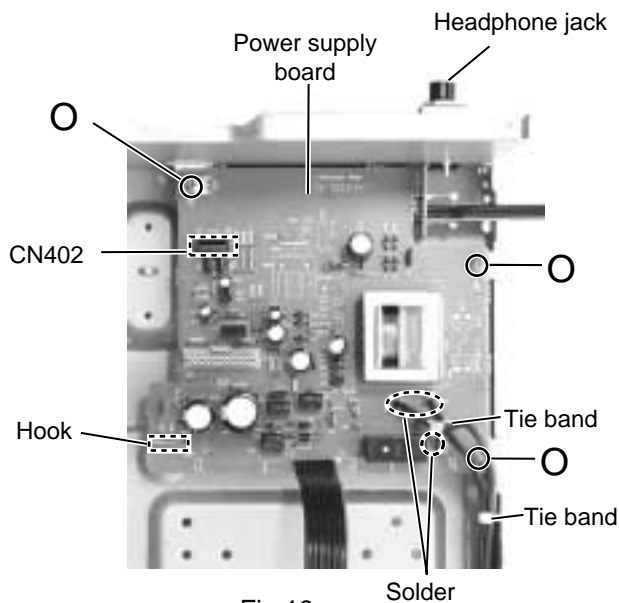

Fig.19



## ■ Removing the system control board / power switch board (See Fig.20 to 22)

- Prior to performing the following procedure, remove the top cover and the front panel assembly.
1. Pull out the volume knob on the front side of the front panel and remove the nut attaching the system control board.
  2. Remove the two screws P attaching the power switch board.
  3. Remove the two screws Q attaching the switch board.
  4. Remove the cords from the three hooks a.
  5. Remove the eight screws R attaching the system control board on the back of the front panel.
  6. On the back of the front panel, release the four joints by pushing the joint tabs inward. Remove the operation switch panel toward the front.
  7. Disconnect the harness from connector CN420 and CN422 on the system control board.
  8. Release the two hooks b attaching the system control board.

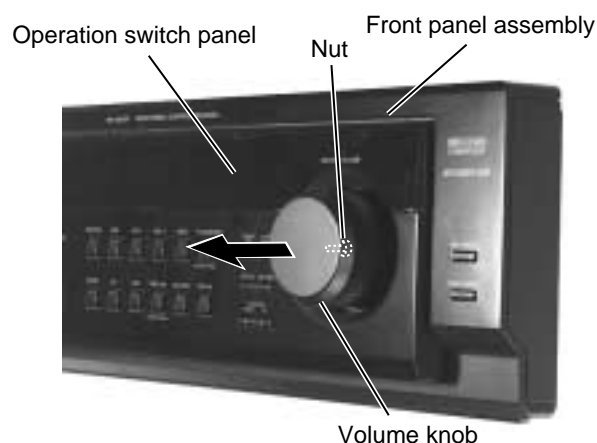

Fig.20

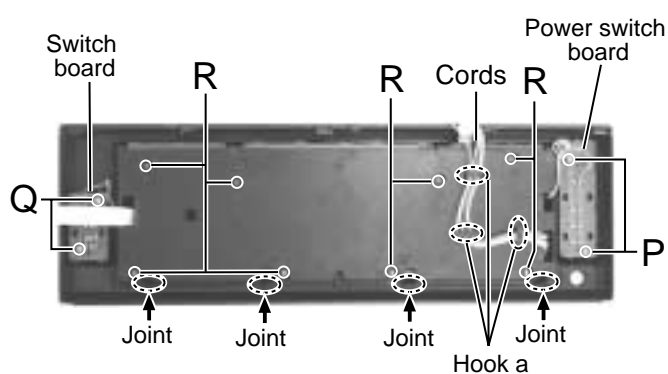

Fig.21

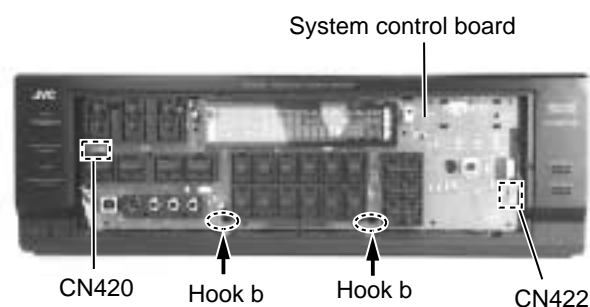
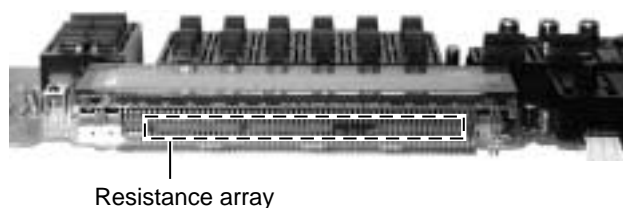

Fig.22

## ■ Matters that require attention during replacement of IC400

- In case where there is a resistance array:  
Both onetime IC and mask IC can be used
- In case where there is no resistance array:  
Only mask IC can be used



# Adjustment method

## ■ Tuner section

### 1. Tuner range

FM	87.5MHz~108.0MHz
AM(MW)	530kHz~1710kHz

## ■ Power amplifier section

### Adjustment of idling current

Measurement location	B2204-B2205(Lch) , B2213-2214(Rch)
Adjustment part	VR787(Lch) , VR788(Rch)

### Attention

**This adjustment does not obtain a correct adjustment value immediately after the amplifier is used (state that an internal temperature has risen). Please adjust immediately after using the amplifier after turning off the power supply of the amplifier and falling an internal temperature.**

### <Adjustment method>

1. Set the volume control to minimum during this adjustment. (No signal & No load)
2. Set the surround mode OFF.
2. Turn VR787 and VR788 fully counterclockwise to warm up before adjustment.  
If the heat sink is already warm from previous use the correct adjustment can not be made.
3. For L-ch, connect a DC voltmeter between B2204 and B2205 (Lch)  
And, connect it between B2213 and B2214 (Rch).
4. 30 minutes later after power on, adjust VR787 for L-ch, or VR788 for R-ch so that the DC voltmeter value has 1mV~10mV.

\* It is not abnormal though the idling current might not become 0mA even if it is finished to turn variable resistance (VR787, VR788) in the direction of counterclockwise.

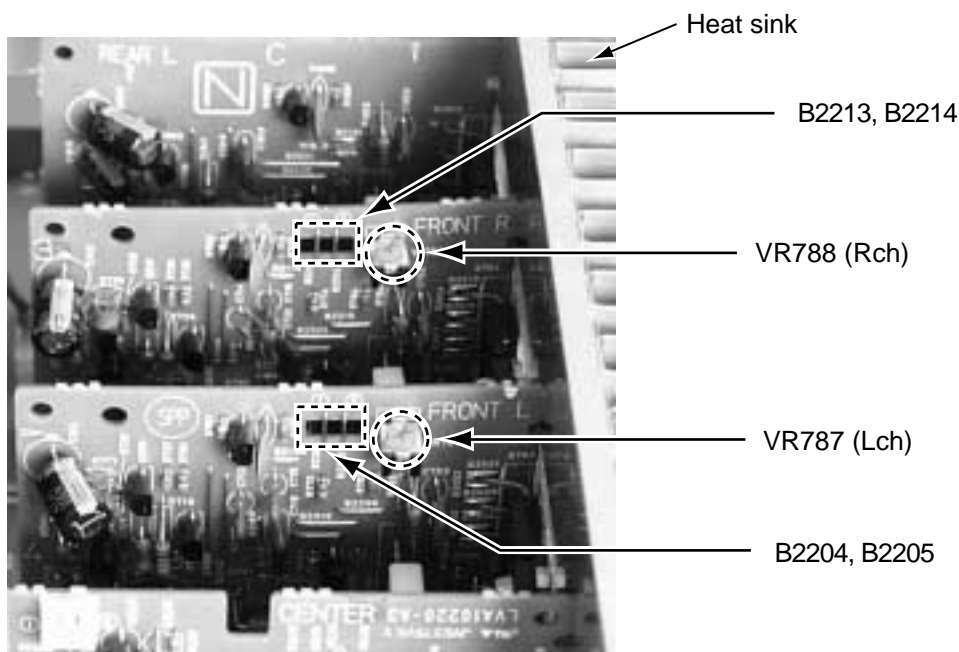

# Self-diagnose function

## 1. Detection of abnormal power supply and voltage

- When the power is turned ON, if an abnormality is detected during the signal input at the A/D port (IC901, pin 2-5, 7) for one second continuously, the status will become STANDBY mode immediately.
- When the power is turned ON again, detection of abnormal power supply and voltage will not be carried out during the first 4 seconds.
- Given below is a list of threshold values at the detection of abnormalities.

	At abnormal state (Low voltage)	At abnormal state	At abnormal state (High voltage)
Pin 2 Micro-computer+5V	Analog value 0 - 2.2V	Analog value 2.2 - 2.8V	Analog value 2.8 - 5.0V
Pin 3 Digital+5V	Analog value 0 - 2.2V	Analog value 2.2 - 2.8V	Analog value 2.8 - 5.0V
Pin 4 Analog+5V	Analog value 0 - 2.2V	Analog value 2.2 - 2.8V	Analog value 2.8 - 5.0V
Pin 5 +12V	Analog value 0 - 2.2V	Analog value 2.2 - 2.8V	Analog value 2.8 - 5.0V
Pin 7 Tuner+9V	Analog value 0 - 2.2V	Analog value 2.2 - 2.8V	Analog value 2.8 - 5.0V

## 2. Initial setting on ship

- To gain the initial setting on ship, put the power plug in the socket while pressing DOWN key and UP key together simultaneously, then turn the power ON.

## 3. Test mode

- To enter the test mode, put the power plug in the socket while pressing EFFECT key and UP key together simultaneously, then turn the power ON.
- Workings of test mode:
  - ① All FLs are turned ON for 3 seconds. (the FLs, which are divided in two groups, are turned ON alternatively)
  - ② A Faster volume UP/DOWN operation can be achieved with the remote controller.
- When the power is turned OFF, the test mode will be released.
- The FL display returns to normal after the three seconds. Then the STANDBY LED is turned ON (flashing ON and OFF for each one second) to show the present status being a test mode.

#### 4. Self-diagnose

- To enter the self-diagnose mode, put the power plug in the socket while pressing SETTING key and UP key together simultaneously, then turn the power ON. With the UP/DOWN key operation, DSP microcomputer, ROM No.of system microcomputer as well as working status of DSP can be displayed for five seconds. While the working status is being displayed, the followings items can be switched with the UP/DOWN key operation.

VERSION of system microcomputer → Local microcomputer CH0 →  
 Local microcomputer CH01 → Local microcomputer CH2 →  
 Local microcomputer CH3 → Local microcomputer CH4

- When the power is turned OFF, the self-diagnose mode will be released.
- During the self-diagnose mode, the STANDBY LED is turned ON .  
 (flashing ON for one second then OFF for three seconds)
- FL transient display will be carried out as follows. When the transient display is not carried out, normal display/workings are carried out.

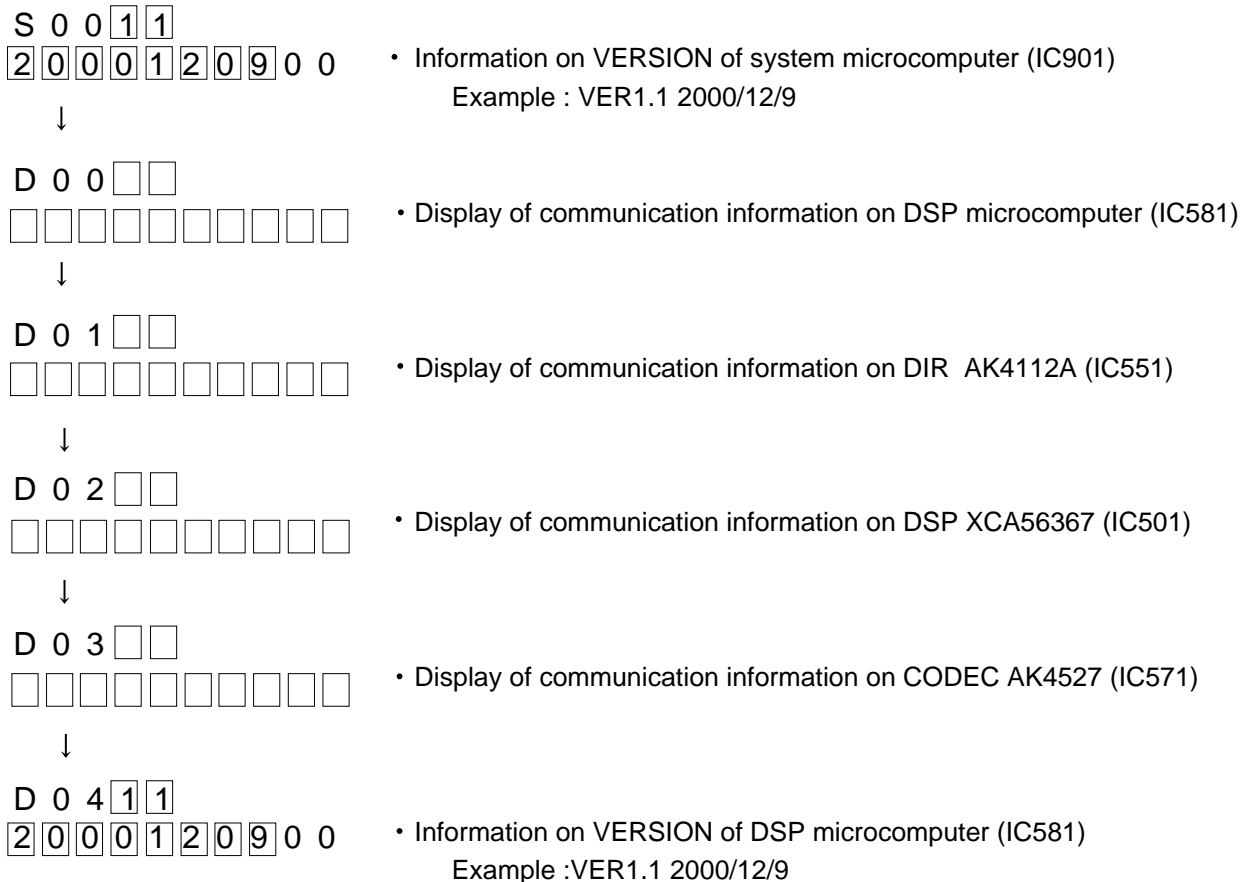
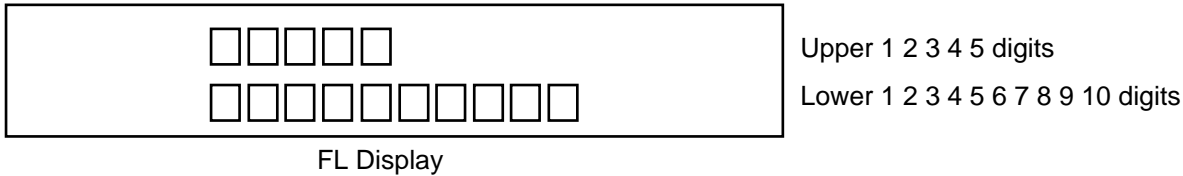

# Description of major ICs

## ■ AK4527 (IC571) : A/D,D/A Converter

1.Pin layout

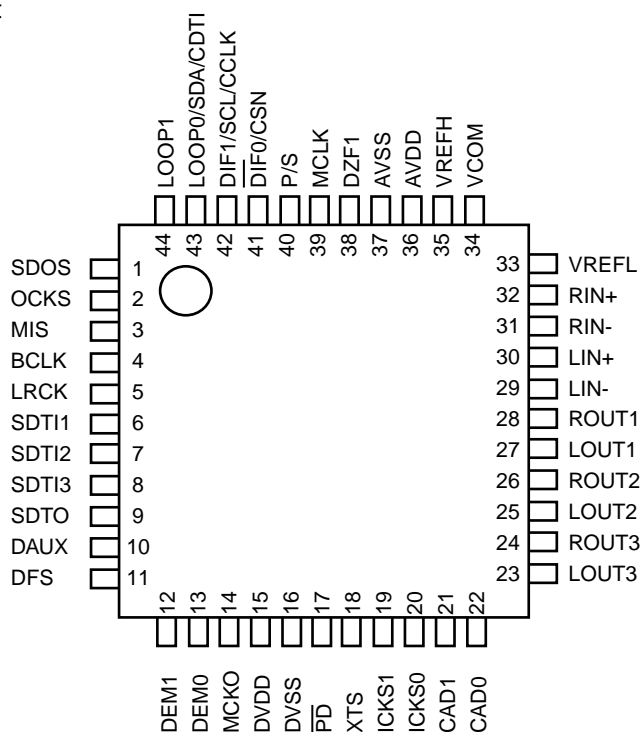

2.Block diagram

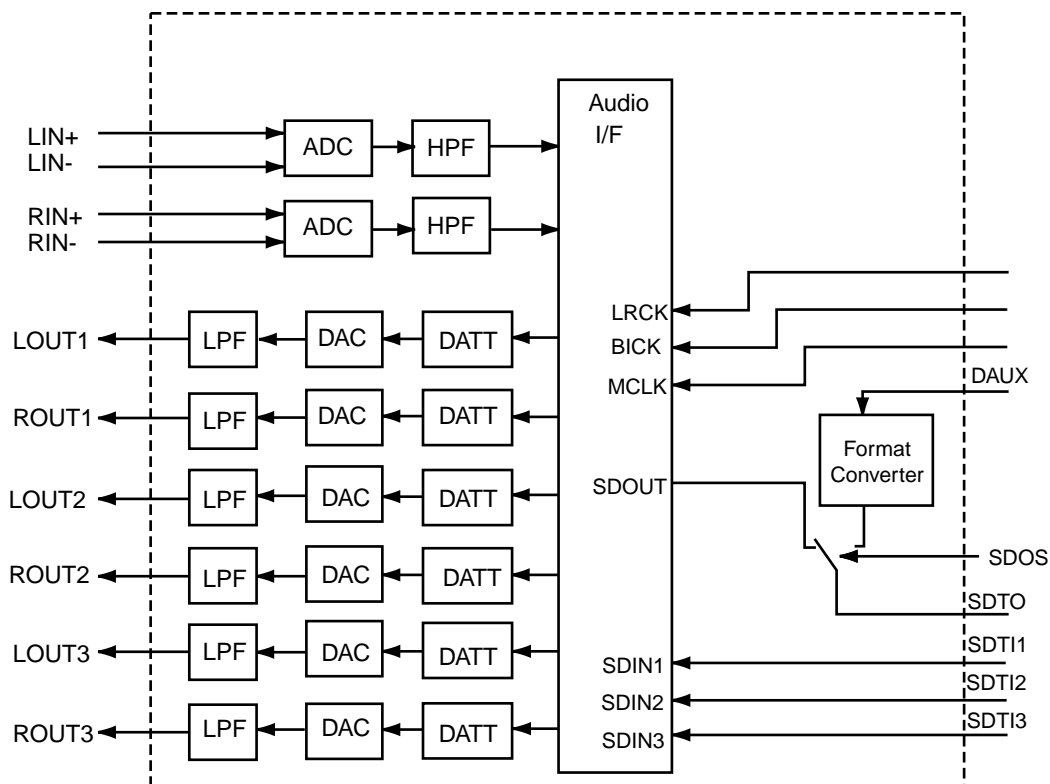

Block Diagram (DIR and AC-3) DSP are external parts)

## 3. Pin function (1/2)

AK4527(1/2)

No.	Pin name	I/O	Function
1	SDOS	I	SDTO Source select pin "L" : Internal ADC output, "H" : DAUX input ORed with serial control register if P/S="L".
2	OCKS	I	MCKO Clock frequency select pin "L" : MCLK, "H" : MCLK/2. ORed with serial control register if P/S="L".
3	MIS	I	Connect to GND
4	BICK	I	Audio serial data clock pin
5	LRCK	I/O	Input/Output channel clock pin
6	SDTI1	I	DAC1 Audio serial data input pin
7	SDTI2	I	DAC2 Audio serial data input pin
8	SDTI3	I	DAC3 Audio serial data input pin
9	SDTO	O	Audio serial data output pin
10	DAUX	I	AUX Audio serial data input pin
11	DFS	I	Double speed sampling mode pin "L" : Normal speed, "H" : Double speed, the ADC is powered down. ORed with serial control register if P/S="L".
12	DEM1	I	De-emphasis pin ORed with serial control register if P/S="L"
13	DEM0	I	De-emphasis Pin ORed with serial control register if P/S="L"
14	MCKO	O	Master clock output pin
15	DVDD	-	Digital power supply pin
16	DVSS	-	Digital ground pin
17	PD	I	Power-down & Reset pin When "L", the AK4527 is powered-down and the control registers are reset to default state. If the state of CAD0-1 changes, then the AK4527 must be reset by PDN.
18	XTS	I	X'tal oscillator Select/Test mode pin "H" : X'tal Oscillator selected "L" : External clock source selected
19	ICKS1	I	Input clock select 1 pin
20	ICKS0	I	Input clock select 0 pin
21	CAD1	I	Chip address pin Used during the serial control mode.
22	CAD0	I	Chip address pin Used during the serial control mode.
23	LOUT3	O	Lch #3 analog output pin
24	ROUT3	O	Rch #3 analog output pin
25	LOUT2	O	Lch #2 analog output pin
26	ROUT2	O	Rch #2 analog output pin
27	LOUT1	O	Lch #1 analog output pin
28	ROUT1	O	Rch #1 analog output pin
29	LIN-	I	Lch analog negative Input Pin
30	LIN+	I	Lch analog positive Input Pin
31	RIN-	I	Rch analog negative Input Pin
32	RIN+	I	Rch analog positive Input Pin

## 3.Pin function (2/2)

AK4527(2/2)

No.	Pin Name	I/O	Function
33	VREFL	I	Negative voltage reference Input pin, AVSS
34	VCOM	O	Common voltage output pin,AVDD/2 Large external capacitor around 2.2uF is used to reduce power-supply noise
35	VREFH	I	Positive voltage reference input pin,AVDD
36	AVDD	-	Analog power supply pin
37	AVSS	-	Analog ground pin
38	XTI	I	X'tal input pin
39	XTO	O	X'tal output pin if XTS="H"
	MCKI	I	External master clock input pin if XTS="L"
40	P/S	I	Parallel/Serial select pin "L" : Serial control mode, "H" : Parallel control mode
41	DIF0	I	Audio data interface format pin in parallel mode
	CS	I	Chip select pin in serial mode
42	DIF1	I	Audio data interface format pin in parallel mode
	CCLK	I	Control data clock pin in serial mode
43	LOOP0	I	Loop back mode pin in parallel mode Enables digital loop-back from ADC to 3 DACs.
	CDTI	I	Control data input pin in serial mode
44	LOOP1	I	Loop back mode pin in parallel mode Enable all 3 DAC channels to be input from SDTII.
	CDTO	O	Control data output pin in serial mode

■ BA15218F(IC303, IC304, IC372, IC385, IC386) : OP AMP.

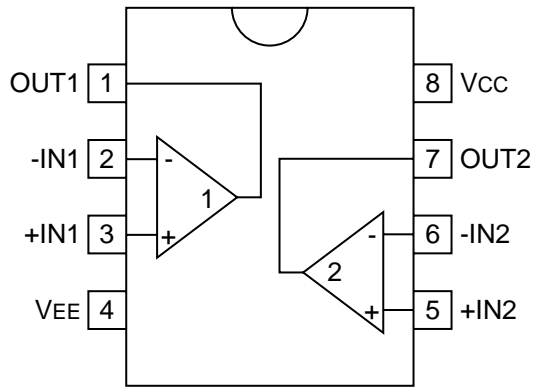

■ BA7625 (IC201, IC242) : Video selector

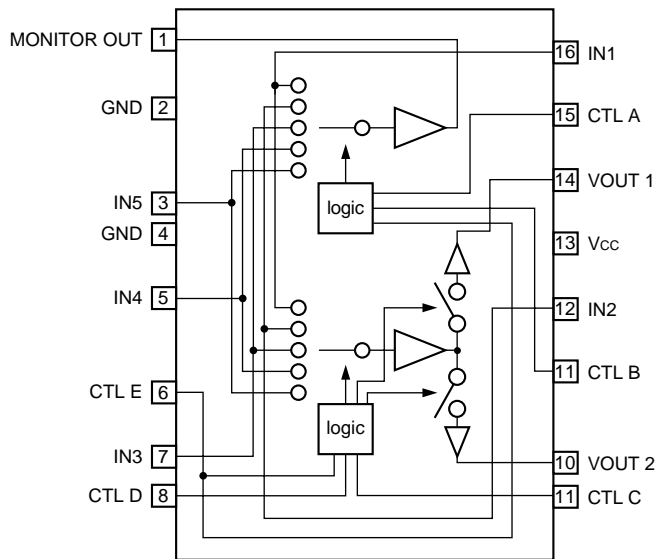

A	B	E	MONITOR OUT
L	L	*	IN1
H	L	*	IN2
L	H	*	IN3
H	H	L	IN4
H	H	H	IN5

C	D	E	VOUT1
L	L	*	--
H	L	*	IN2
L	H	*	IN3
H	H	L	IN4
H	H	H	IN5

C	D	E	VOUT2
L	L	*	IN1
H	L	*	--
L	H	*	IN3
H	H	L	IN4
H	H	H	IN5

■ BA7626 (IC241) : Video selector

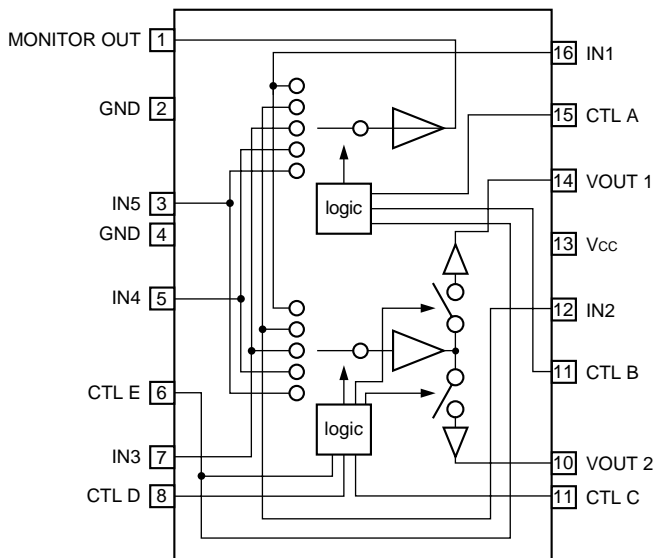

A	B	E	MONITOR OUT
L	L	*	IN1
H	L	*	IN2
L	H	*	IN3
H	H	L	IN4
H	H	H	IN5

C	D	E	VOUT1
L	L	*	--
H	L	*	IN2
L	H	*	IN3
H	H	L	IN4
H	H	H	IN5

C	D	E	VOUT2
L	L	*	IN1
H	L	*	--
L	H	*	IN3
H	H	L	IN4
H	H	H	IN5



## ■ BU2092(IC402):PORT EXPANDER

### 1. Terminal Layout

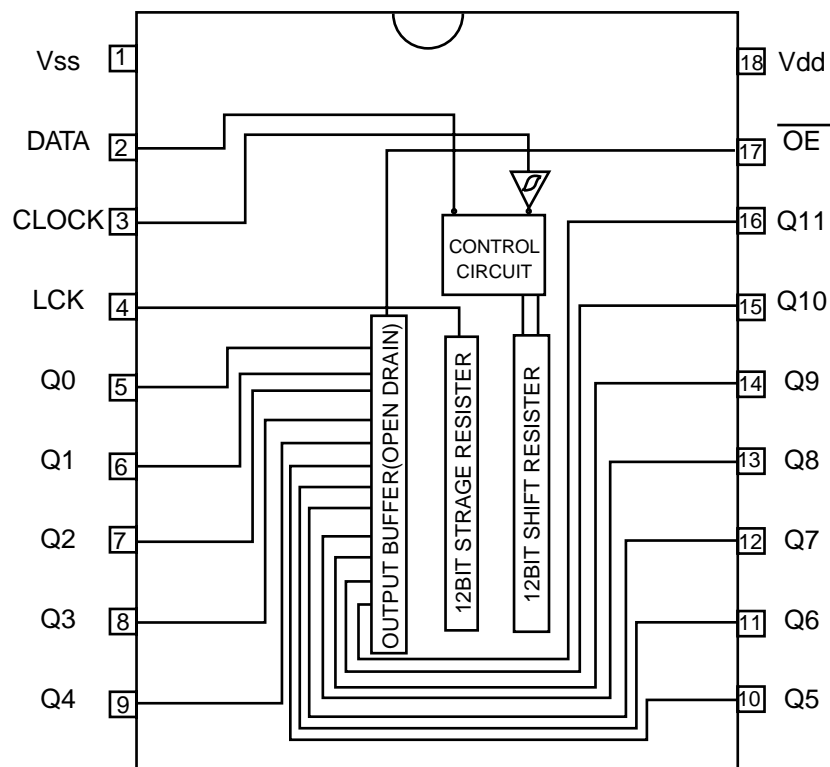

### 2.Pin Function

Pin No.	Symbol	I/O	Function						
1	Vss	-	Connect to GND						
2	DATA	I	Serial Data input						
3	CLOCK	I	Shift Clock of Data						
4	LCK	I	Latch Clock of Data						
5~16	Q0~Q11	O	Parallel Data Output <table border="1" style="margin-left: 20px;"> <tr> <td>Latch Data</td> <td>L</td> <td>H</td> </tr> <tr> <td>OUTPUT</td> <td>ON</td> <td>OFF</td> </tr> </table>	Latch Data	L	H	OUTPUT	ON	OFF
Latch Data	L	H							
OUTPUT	ON	OFF							
17	$\overline{\text{OE}}$	I	Output Enable						
18	Vdd	-	Power Supply						

■ MB90088 (IC203) : On screen display controller

1. Terminal Layout

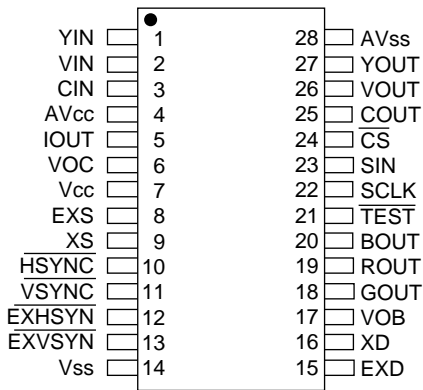

2. Block Diagram

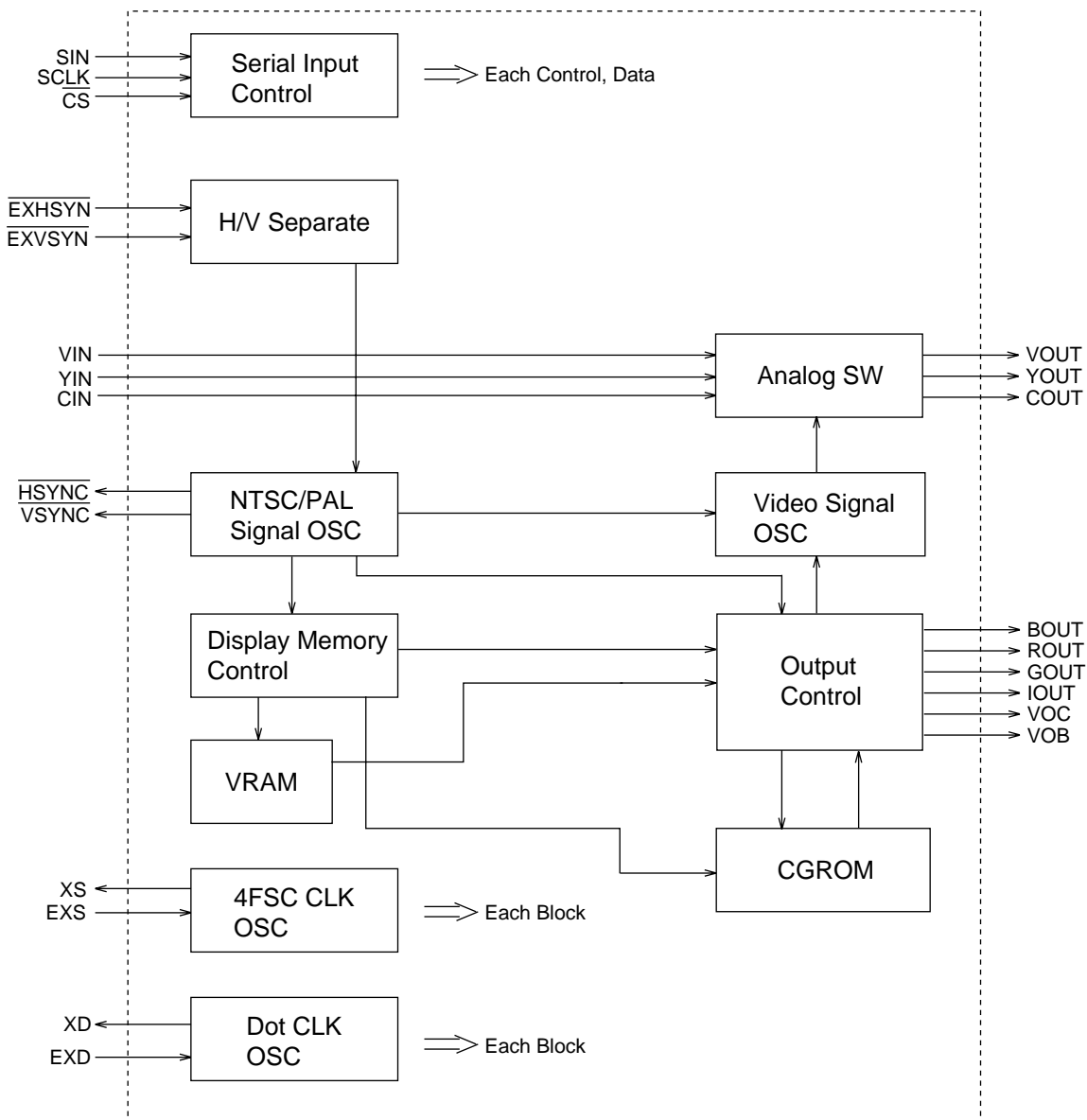

## 3.Functions

pin no	Symbol	I/O	Function
1	YIN	I	Lux signal Input terminal for Superinpause indication
2	VIN	I	Composite video signal input terminal for Superinpause indication
3	CIN	I	Contrast signal input terminal for Superinpause indication
4	AVcc	-	Analog power supply terminal
5	IOUT	O	Color (Lux) signal output terminal
6	VOC	O	Character output terminal
7	Vcc	-	Power supply terminal
8	EXS	I	Clock generater outside circuit terminal for color burst
9	XS	O	
10	$\overline{\text{HSYNC}}$	O	Horizontal signal output terminal
11	$\overline{\text{VSYNC}}$	O	Vertical signal output terminal
12	$\overline{\text{EXHSYN}}$	I	EXT horizontal signal input terminal
13	$\overline{\text{EXVSYN}}$	I	EXT vertical signal input terminal
14	Vss	-	GND
15	EXD	I	Dot clock generater outside circuit signal terminal for indication
16	XD	O	
17	VOB	O	Character & background signal output terminal
18	GOUT	O	Color signal (Green, Red, Blue)
19	ROUT		
20	BOUT		
21	$\overline{\text{TEST}}$	I	Test signal input terminal
22	SCLK	I	Shift clock input terminal for serial transmission
23	SIN	I	Serial data input terminal
24	$\overline{\text{CS}}$	I	Chip select terminal
25	COUT	O	Contrast signal output terminal
26	VOUT	O	Composite video signal output terminal
27	YOUT	O	Lux signal output terminal
28	AVss	-	Analog GND terminal

■ MAX4018ESD (IC390) : OP AMP.

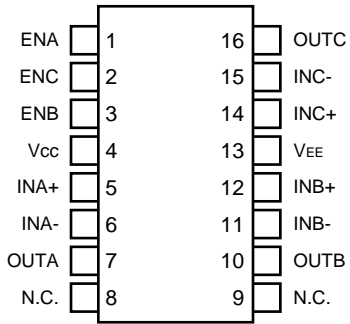

■ NJM2285V-W(IC202) : 2-INPUT 3CHANNEL VIDEO SWITCH

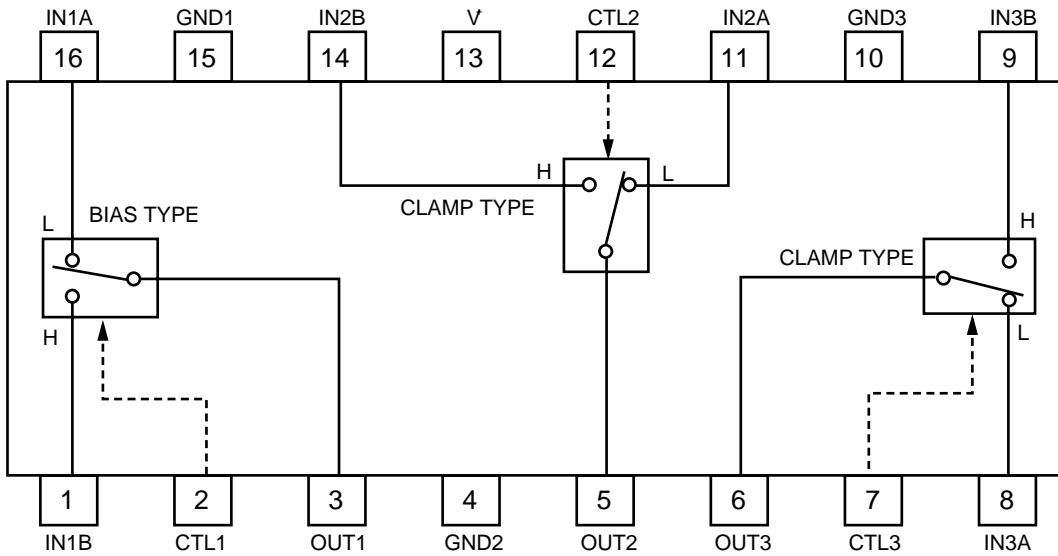

■ NJM4580D (IC301) : LPF, Mic and H.phone Amp.

1.Terminal layout

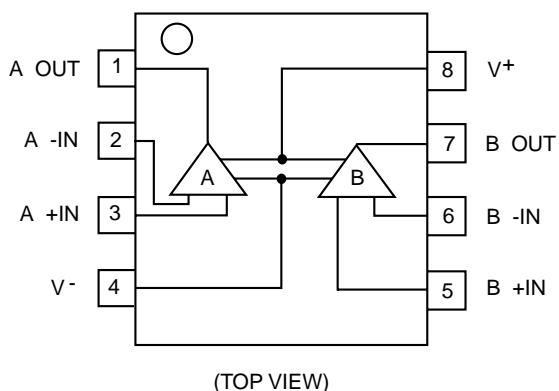

2.Block diagram

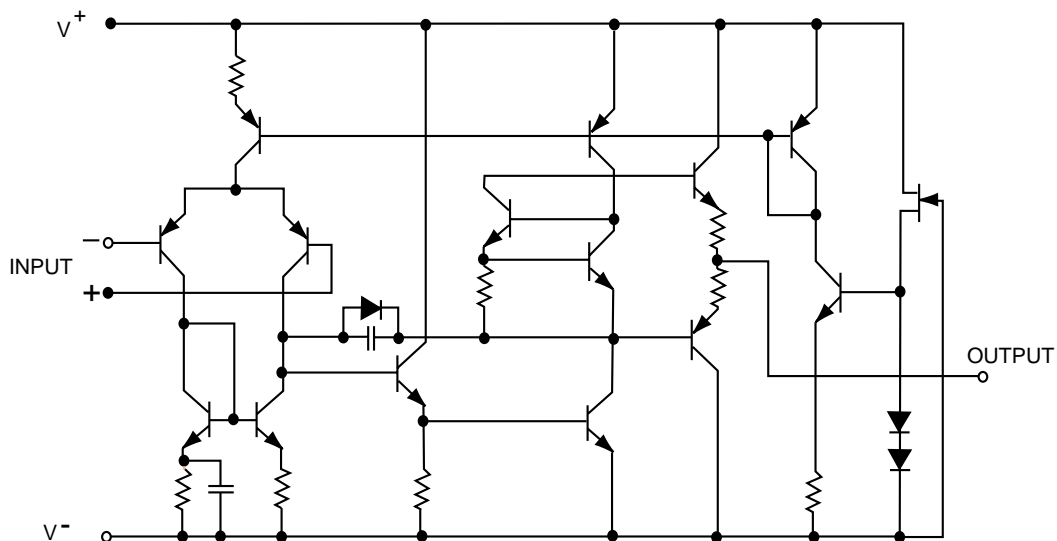

■ NJU7241F33(IC411) : VOLTAGE REGULATOR

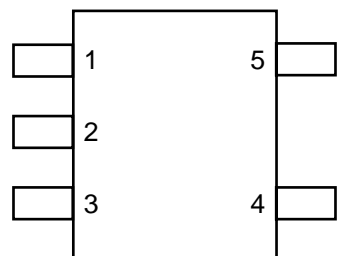

- PIN FUNCTION
- 1. GND
  - 2. V<sub>IN</sub>
  - 3. V<sub>OUT</sub>
  - 4. +NC
  - 5. STB

## ■ PCM2702E-X (IC410) : DIGITAL / ANALOG CONVERTER

### 1. Pin layout

1	XTI	XTO	28
2	VDDC	VCCP	27
3	DGNDC	AGNDP	26
4	VDD	VCCL	25
5	DGND	AGNDL	24
6	D+	VOUTL	23
7	D-	VCC	22
8	VBUS	VCOM	21
9	DGND	AGND	20
10	PLYBCK	VOUTR	19
11	SSPND	AGNDR	18
12	ZERO	VCCR	17
13	TEST3	TEST0	16
14	TEST2	TEST1	15

### 2. Block diagram

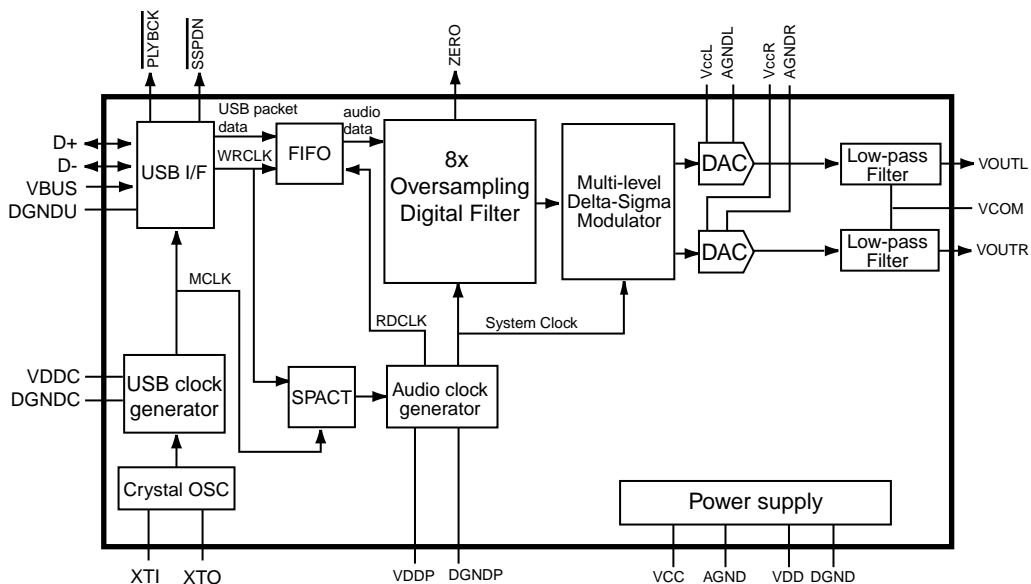

### 3. Pin function

PIN	Symbol	I/O	Function
1	XTI	IN	Crystal Oscillator Input. (1)
2	VDDC	-	Digital Power Supply for Clock Generator, +3.3V.
3	DGNDC	-	Digital Ground for Clock Generator.
4	VDD	-	Digital Power Supply, +3.3V.
5	DGND	-	Digital Ground.
6	D+	I/O	USB Differential Input/Output Plus.
7	D-	I/O	USB Differential Input/Output Minus.
8	VBUS	IN	USB Bus Power (This pin NEVER consumes the USB bus power). (2)
9	DGNDU	-	Digital Ground for USB Transceiver.
10	PLYBCK	OUT	Playback flag, active LOW. (LOW: playback, HIGH: idle).
11	SSPND	OUT	Suspend flag, active LOW. (LOW: suspend, HIGH: operational).
12	ZERO	OUT	Zero flag, (LOW: Normal, HIGH: ZERO).
13	TEST3	IN	Test pin 3. Connect to digital ground. (2)
14	TEST2	IN	Test pin 2. Connect to digital ground. (2)
15	TEST1	IN	Test pin 1. Connect to digital ground. (2)
16	TEST0	IN	Test pin 0. Connect to digital ground. (2)
17	VCCR	-	Analog Supply for R-channel, +5V.
18	AGNDR	-	Analog Ground for R-channel.
19	VOUTR	OUT	Analog Output for R-channel.
20	AGND	-	Analog Ground.
21	VCOM	-	Common for DAC.
22	VCC	-	Analog Supply, +5V.
23	VOUTL	OUT	Analog output for L-channel.
24	AGNDL	-	Analog Ground for L-channel.
25	VCCL	-	Analog Supply for L-channel, +5V.
26	AGNDP	-	Analog Ground for PLL.
27	VCCP	-	Analog Supply for PLL, +5V.
28	XTO	OUT	Crystal Oscillator Output.

Note:

- (1) 3.3V tolerant.
- (2) Schmitt trigger input with internal pull-down, 5V tolerant.

■ TC9162AN (IC380) : ANALOG SWITCH

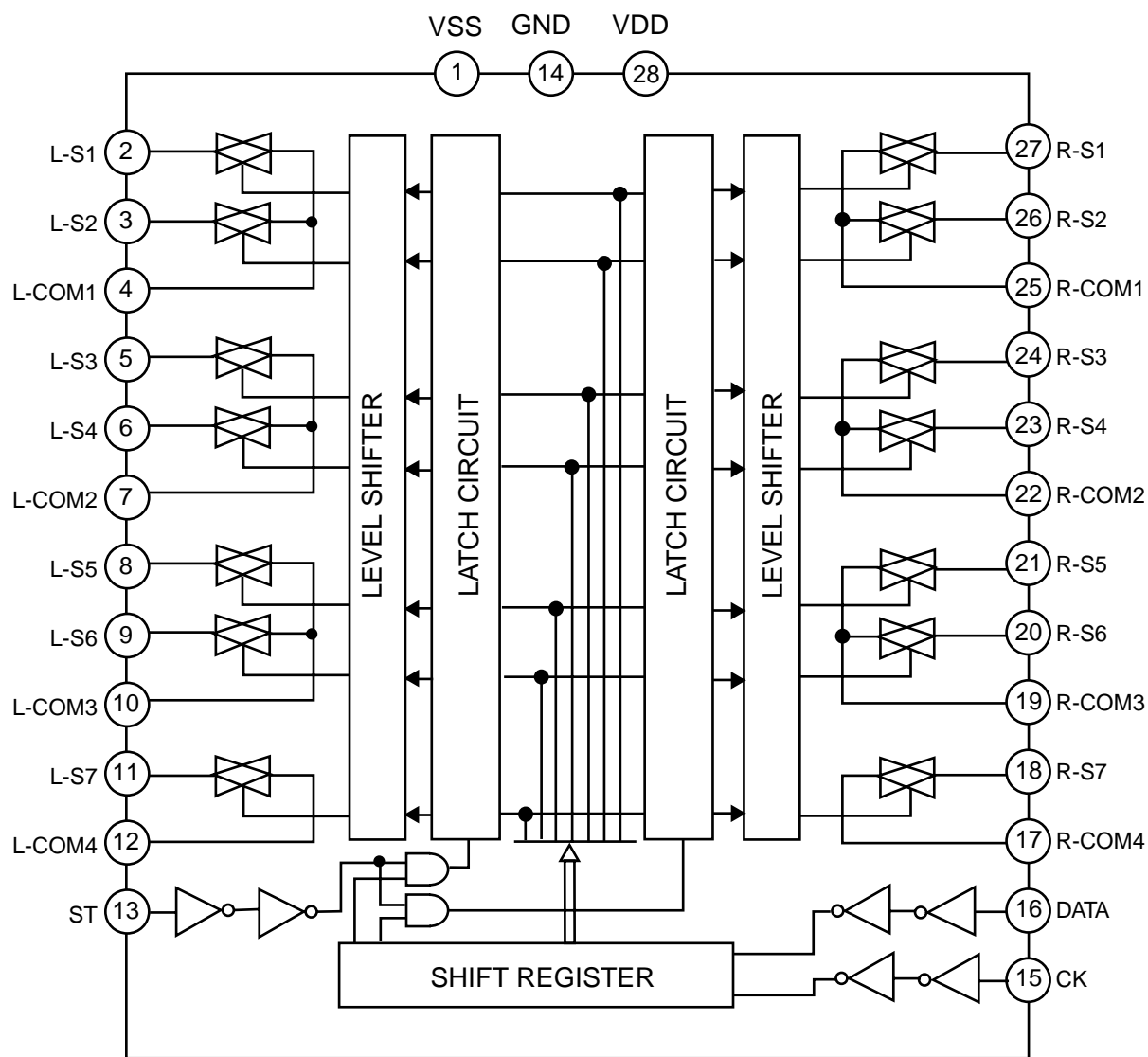
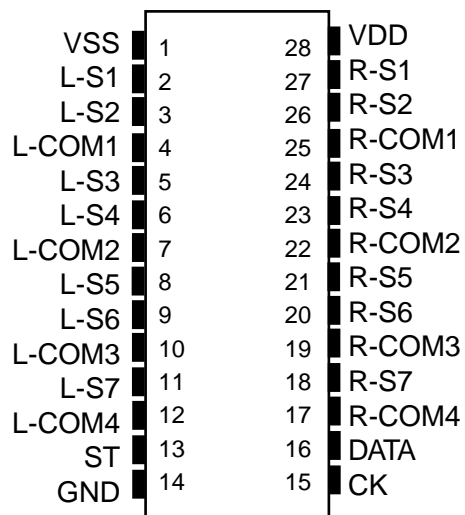

■ TC9163AF-X (IC371) : ANALOG SWITCH

VSS	1	28	VDD
L-S1	2	27	R-S1
L-S2	3	26	R-S2
L-S3	4	25	R-S3
L-COM1	5	24	R-COM1
L-S4	6	23	R-S4
L-S5	7	22	R-S5
L-S6	8	21	R-S6
L-COM2	9	20	R-COM2
L-S7	10	19	R-S7
L-S8	11	18	R-S8
L-COM3	12	17	R-COM3
ST	13	16	DATA
GND	14	15	CK

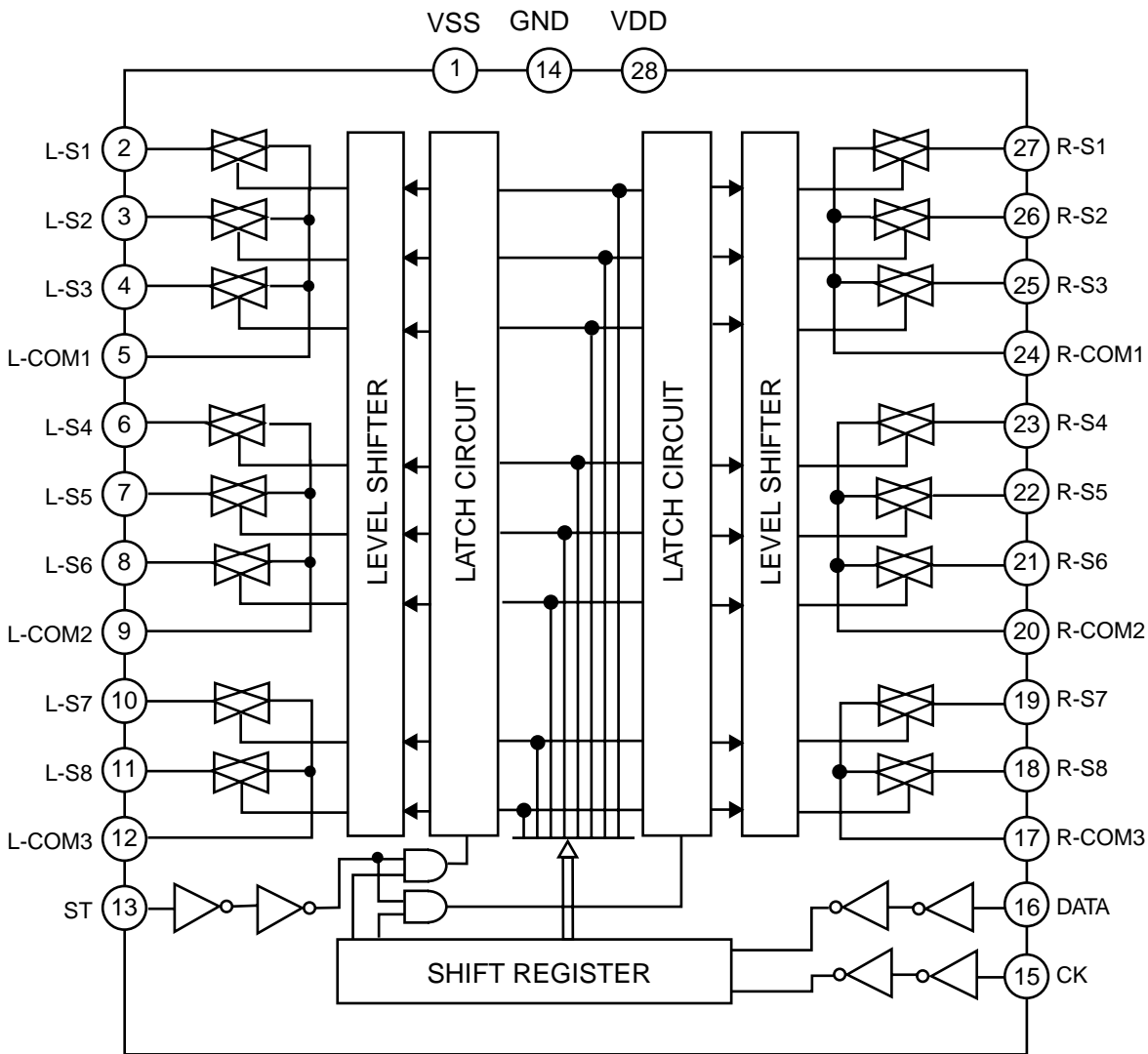



■ TC9164AF-X (IC302) : ANALOG SWITCH

VSS	1	28	VDD
L-S1	2	27	R-S1
L-S2	3	26	R-S2
L-S3	4	25	R-S3
L-S4	5	24	R-S4
L-COM1	6	23	R-COM1
L-S5	7	22	R-S5
L-S6	8	21	R-S6
L-COM2	9	20	R-COM2
L-S7	10	19	R-S7
L-S8	11	18	R-S8
L-COM3	12	17	R-COM3
ST	13	16	DATA
GND	14	15	CK

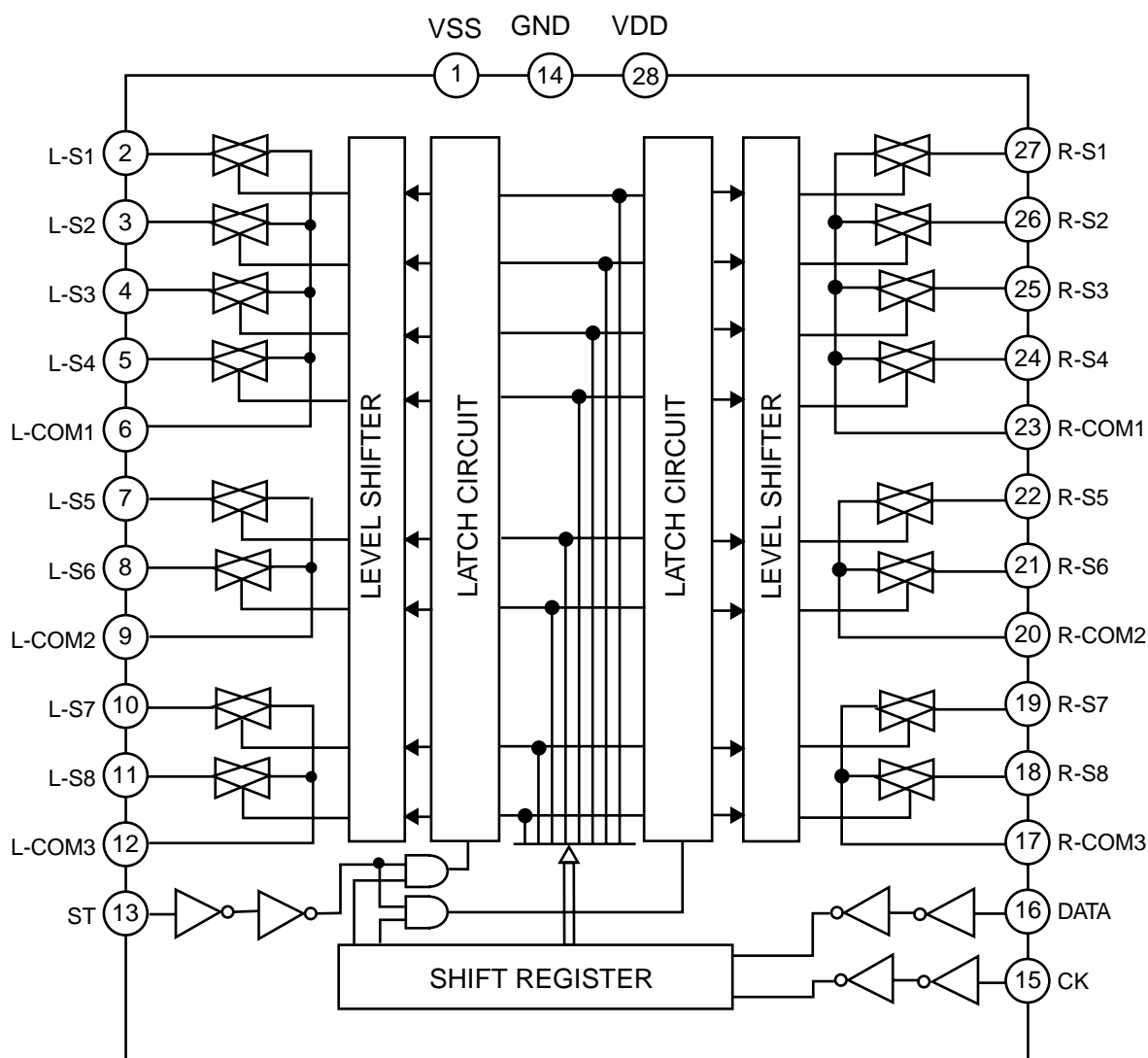

■ TC9459F (IC381, IC382, IC383) : Electronic volume control

1. Terminal layout

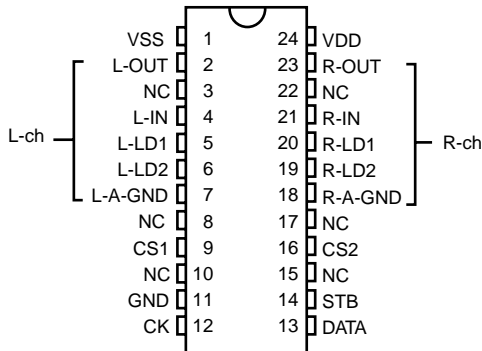

2. Block diagram

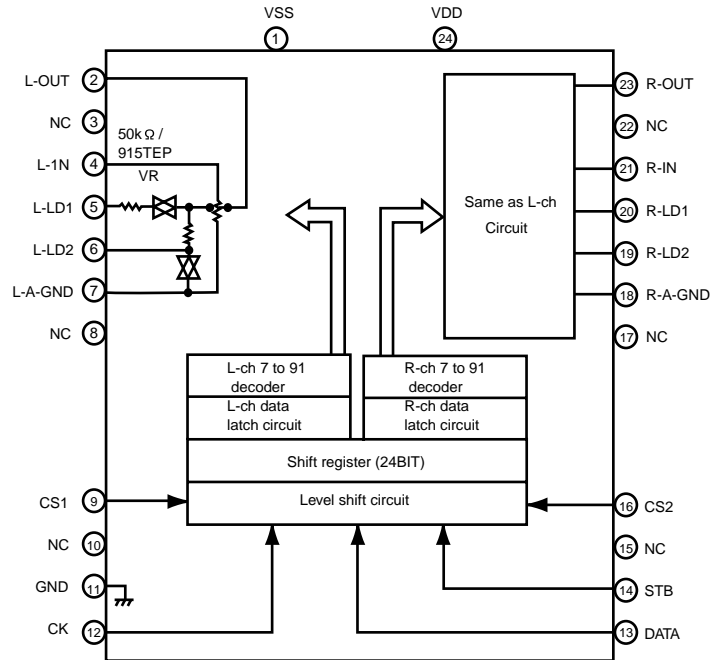

3. Pin function

Pin No.	Symbol	Function	Pin No.	Symbol	Function
1	VSS	Negative power supply pin	13	DATA	Data input pin
2	L-OUT	Volume output pin	14	STB	Strobe input pin
3	NC	No connection	15	NC	No connection
4	NC	No connection	16	CS2	Chip select input pin
5	L-LD1	Loudness tap output pin	17	NC	No connection
6	L-LD2	Loudness tap output pin	18	R-A-GND	Analog GND pin
7	L-A-GND	Analog GND pin	19	R-LD2	Loudness tap output pin
8	NC	No connection	20	R-LD1	Loudness tap output pin
9	CS1	Chip select input pin	21	R-IN	Volume input pin
10	NC	No connection	22	NC	No connection
11	NC	No connection	23	R-OUT	Volume output pin
12	CK	Clock input pin	24	VDD	Positive power supply pin

■ PQ3DZ53 (IC583) : Regulator IC

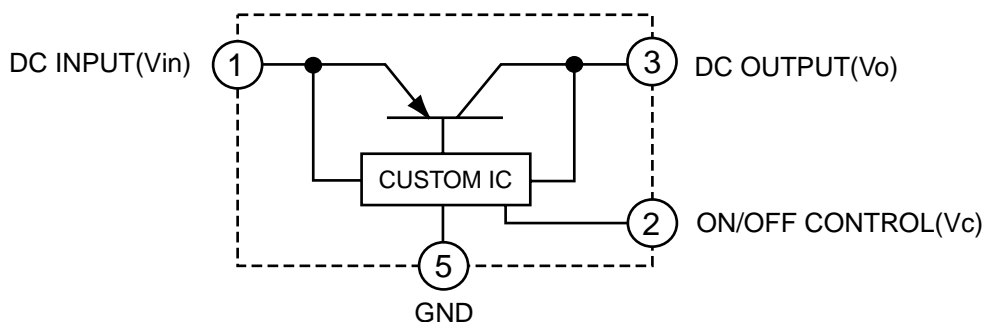

■ TC74HC4053AF (IC388, IC389) : MULTIPLEXER

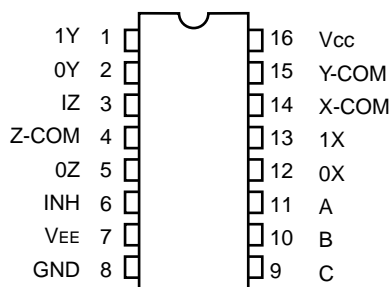

CONTROL INPUTS			
INHIBIT	C	B	A
L	L	L	K
L	L	L	H
L	L	H	K
L	L	H	H
L	H	L	K
L	H	L	H
L	H	H	K
L	H	H	H
H	X	X	X

X: Don't Care.

■ W24L010AJ-12 (IC511) : CMOS STATIC RAM

1. Pin layout

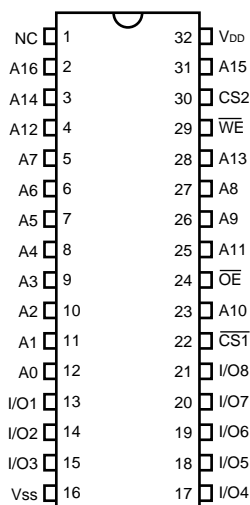

2. Block diagram

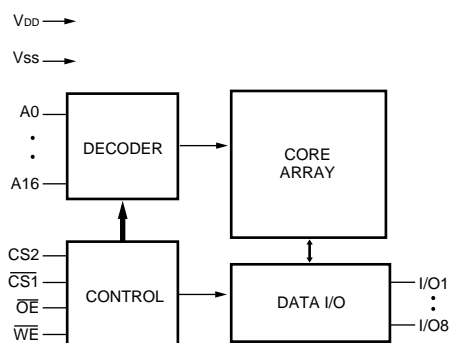

3. Pin function

SYMBOL	DESCRIPTION
A0 - A16	Address Input
I/O1 - I/O8	Data Input/Output
CS1, CS2	Chip Select Inputs
WE	Write Enable Input
OE	Output Enable Input
VDD	Power Supply
Vss	Ground
NC	No Connection

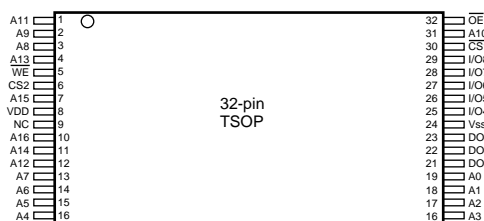

## ■ UPD784215AGC132(IC581) : UNIT CPU

### 1.Pin layout

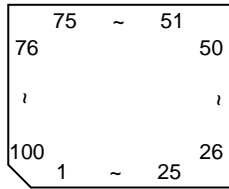

### 2.Pin function

Pin No.	Symbol	I/O	Function
1~8		-	Non connect
9	VDD	-	Power supply terminal
10	X2	-	Connecting the crystal oscillator for system main clock
11	X1		Connecting the crystal oscillator for system main clock
12	VSS	-	Connect to GND
13	XT2	-	Connecting the crystal oscillator for system sub clock
14	XT1		Connect VSS
15	RESET		System reset signal input
16	AUTO		Output of DSP to general-purpose port
17	ERR		Output of DSP to general-purpose port
18	Fz96k		Output of DSP to general-purpose port
19~22	P03~P06		Output of DSP to general-purpose port
23	AVDD	-	Power supply terminal
24	AV REF0	-	Connect to GND
25~32	P10~P17	-	Connect to GND
33	AVSS	-	Connect to GND
34,35	P130, P131	O	Non connect
36	AV REF1	-	Power supply terminal
37,38	RX, TX	O	Not use
39		O	Non connect
40	DSPCOM		Communication port from IC901
41	DSPSTS	O	Status communication port to IC901
42	DSPCLK		Clock input from IC901
43	DSPRDY		Ready signal input from IC901
44		O	Non connect
45,46	MIDIO_IN/OUT	I/O	Interface I/O terminal with microcomputer
47	MICK	O	Interface I/O terminal with microcomputer of clock signal
48	HREQ		HREQ
49	SS	O	System slave select
50,51		-	Non connect
52	DSP_RST	O	Reset signal output of DSP
53		-	Non connect
54	D_CS	O	Chip setselct output
55		-	Non connect
56	PD/ DIR	O	Reset signal output
57~63		-	Non connect
64,65	CDTI/CDTO	O/I	Interface I/O terminal with microcomputer
66	CCLK	O	Interface I/O terminal with microcomputer of clock signal
67	CS	O	CS
68~70		-	Non connect
71	PD	O	Reset signal output
72	GND	-	Connect to GND
73~75		-	Non connect
76	EQ	O	EQ
77	CTR TONE	O	CENTER TONE
78	3D	O	3D-Phonic
79,80		-	Non connect
81	VDD	-	Power supply
82,83		-	Non connect
84	ANA_TT	O	Analog./T.TONE
85	LEF_MIX	O	Select 1
86	LEF_OUT	O	Select 2
87	MIX_OUT	O	Select 3
88	S_MUTE	O	S.MUTE
89~93		-	Non connect
94	TEST	-	Test terminal
95~100		-	Non connect

**RX-8010VBK**

**JVC**

**VICTOR COMPANY OF JAPAN, LIMITED**

AUDIO & COMMUNICATION BUSINESS DIVISION

PERSONAL & MOBILE NETWORK BUSINESS UNIT. 10-1,1chome,Ohwatari-machi,Maebashi-city,371-8543,Japan

(No.20921)

 Printed in Japan  
200103(V)